

# Model: SW1000 Security Lead and Wire Seal

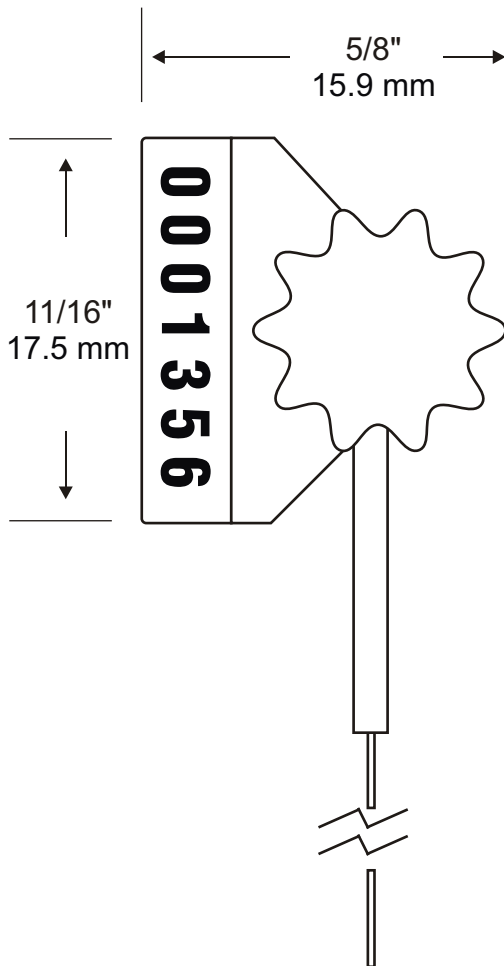

## DESCRIPTION:

AC&M's SW1000 Security Lead and Wire Seals, serves many types of uses. Numbered and lettered tab lead and wire seal for all applications with use of our 5" Bulldog Seal Press. Any length and style of wire already attached or plain leads only.

## PRINTING:

Imprinting available for Security Lead & Wire Seals.  
Lettering up to 10 spaces and numbering up to 6 digits.

## PACKAGING:

• 100 Seals to a carton.

Cartons containing 1,000 seals measure:  
10" x 13" x 17" and weigh 8 Lbs.  
25.4cm x 33cm x 43cm and weigh 3.6 kg.

## USE:

Applies with a 5" Bulldog Seal Press. Cannot be opened unless the seal is destroyed.

*Custom Printing is available —  
Contact AC&M for details.*

# AC&M

**American Casting**  
& Manufacturing Corporation

**Toll-Free (800)342-0333**

Tel: (516) 349-7010 • Fax (516) 349-8389  
email: [info@AmericanCasting.com](mailto:info@AmericanCasting.com)

51 Commercial St · Plainview, NY 11803 USA

[www.AmericanCasting.com](http://www.AmericanCasting.com)