

Model: CL-99-14 Cable Seal

- STANDARD ITEM FROM STOCK:
Pre-Printed / Pre-Numbered
- CUSTOM ORDERED ITEM
Printed & Numbered

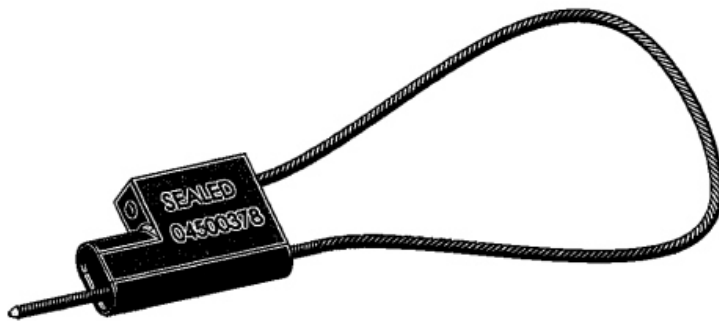
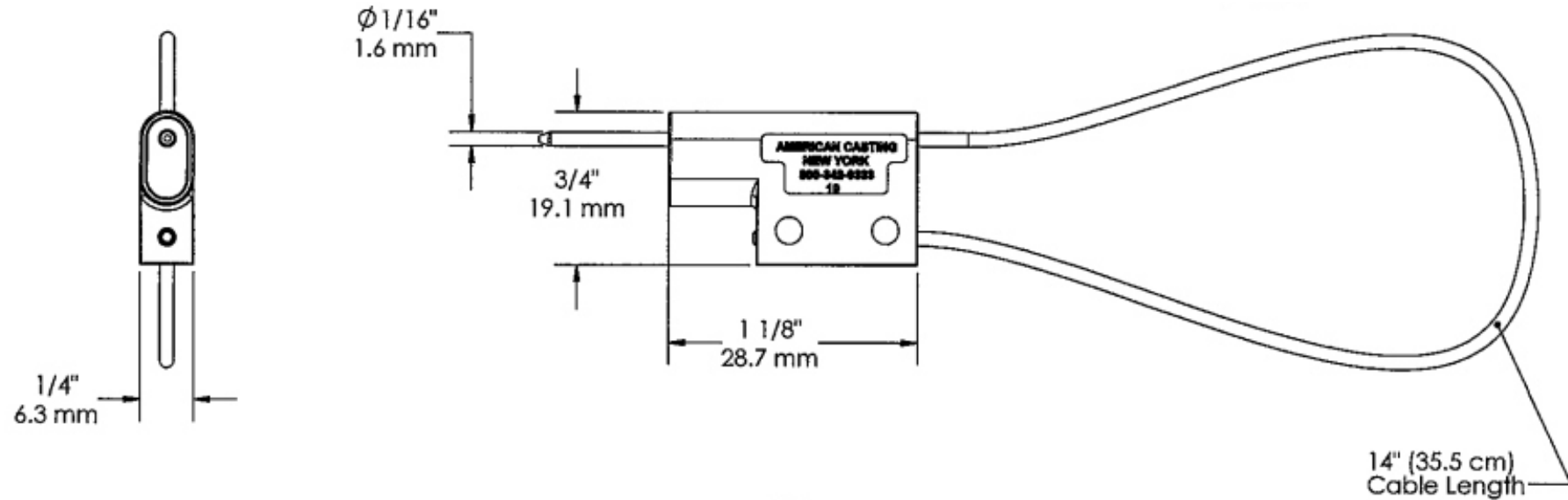

AC&M

American Casting
& Manufacturing Corporation

Toll-Free (800)342-0333

Tel: (516) 349-7010 • Fax (516) 349-8389

email: info@AmericanCasting.com

51 Commercial St · Plainview, NY 11803 USA

*Custom Printing is available —
Contact AC&M for details.*

www.AmericanCasting.com

DESCRIPTION:

AC&M's CL-99-14 Cable Seals, serves many types of uses. Heavy-duty adjustable cable seal for cargo doors, lids, drums, containers with 14" x 1/16" (35.5 cm x 1.6mm) diameter adjustable cable.

PRINTING:

Imprinting available for Cable Seals. One line up to 8 spaces plus one line of consecutive numbers up to 7 digits.

PACKAGING:

- 100 Seals to a poly bag.
- 1,000 Seals to a carton.

Cartons containing 1,000 seals measure: 18" x 12" x 8" and weigh 42 Lbs. 45.7cm x 30.4cm x 20.3cm and weigh 31.8 kg.

USE:

Pull up tight by hand and remove with cable cutter.