

Model: 6001 Speedlock Bag Seal

Available as...

- STANDARD ITEM FROM STOCK:
Pre-Printed / Pre-Numbered
- CUSTOM ORDERED ITEM
Printed & Numbered

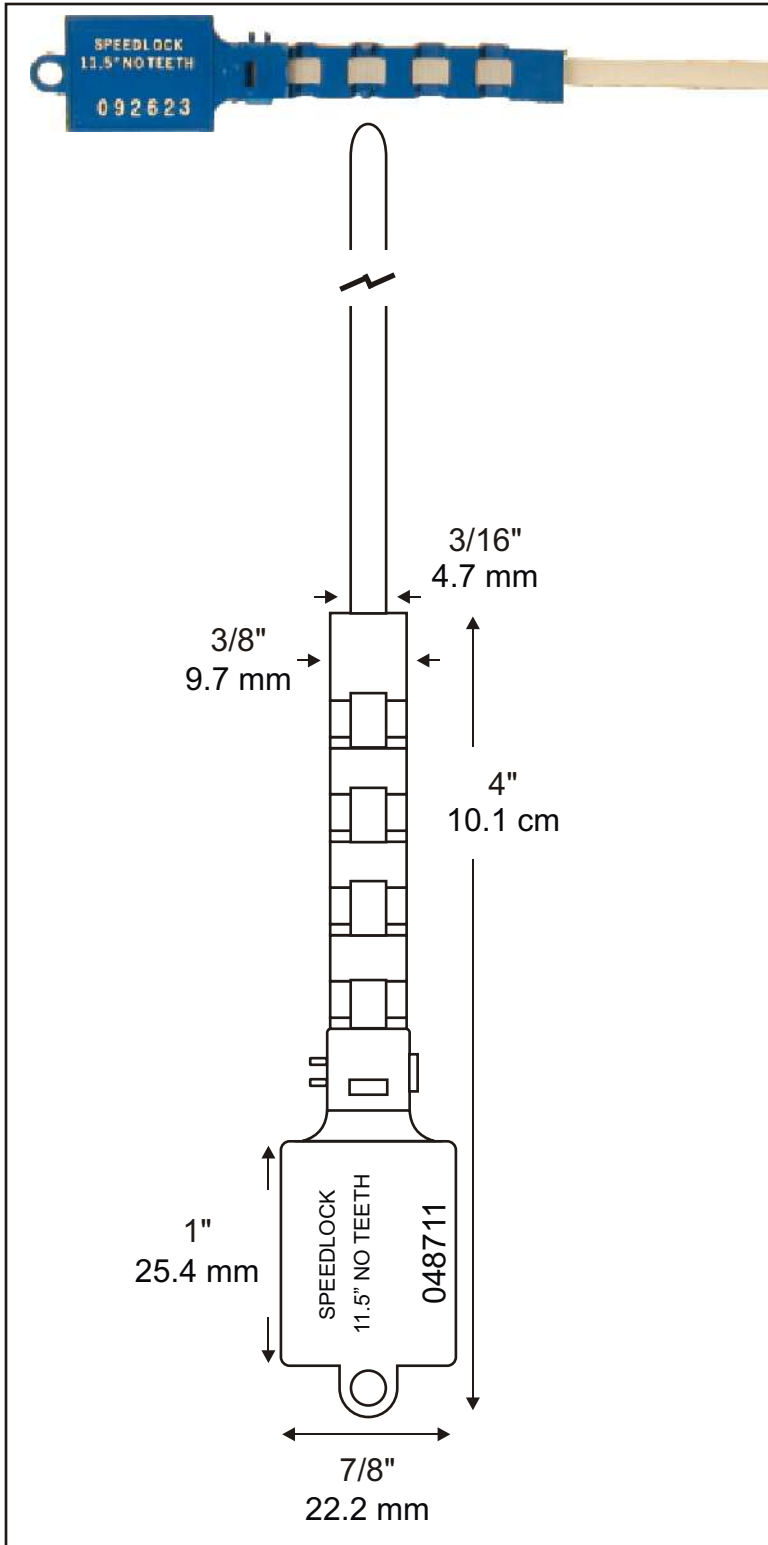

DESCRIPTION:

AC&M's 6001 Speedlock Bag Seals, are all plastic and easy to apply with a standard 7 1/2" (19 cm) strap or optional 11 1/2" (29.2 cm) strap, ideal for securing bags. The teeth grip tight into cloth bags, preventing 'twist-off' tampering. Also available without teeth.

The teeth in Model 6001 grip tight into cloth bags, preventing 'twist-off' tampering. Also available without teeth for plastic bag or non-bag use - call us with your requirements.

BREAKING STRENGTH:

80 Lbs. / 36.3 Kg.

PRINTING:

AC&M's Speedlock Bag Seals are supplied hot-stamped printed. Two lines of print up to 11 spaces per line and 7 digits of consecutive numbering.

PACKAGING:

- 100 Seals to a bag.
- 1,000 Seals to a carton.

Cartons containing 1,000 seals measure:
16" x 12" x 10" Weight: 10 Lbs.
40.6cm x 30.4cm x 25.4cm Weight: 4.5 kg.

USE:

Thread strap through closure and pull tight. Use a Speedlock applicator tool for a tighter grip. Cannot be opened unless the seal is destroyed.

*Custom Printing is available —
Contact AC&M for details.*



American Casting
& Manufacturing Corporation

Toll-Free (800)342-0333

Tel: (516) 349-7010 • Fax (516) 349-8389
email: info@AmericanCasting.com

51 Commercial St · Plainview, NY 11803 USA

www.AmericanCasting.com